

Combo Excelsior Hybrid[®] Foldable IBC

Setting the new standard

Customer Facing PPT



Schoeller Allibert

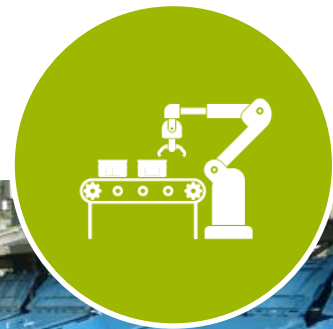

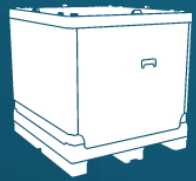

Combo Excelsior®: The new standard folding IBC

Safe, hygienic and efficient

Outstanding performance

Combo Excelsior® is strong and durable : its double wall structure enables a **1,500kg** unit load and a stack load of **8,000kg (4 on 1)**.

Maximum safety when stacked fully loaded, thanks to the T shaped locking system between sides and ends and the smooth double skin lid, self locking, water-tight and featuring strapping locations.

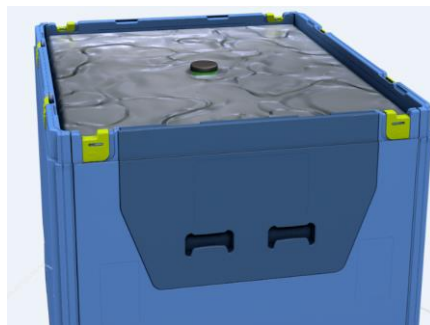
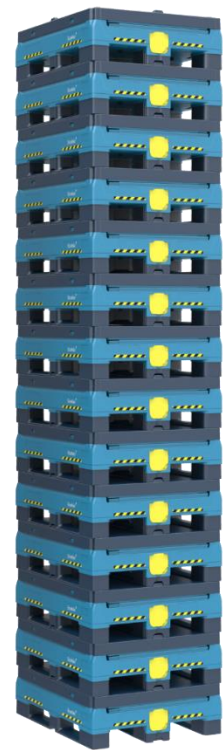

Automated handling

Combo Excelsior® is fully compatible with most of automated handling systems thanks to the reinforced pallet based and 3 skids.

Customization “Smart” RTP

Multiple identification and tracking options with **logo, company name** printing enhancing brand awareness. Multiple **bar code label** and **RFID & IOT** pockets enable efficient fleet management.

Upgrading your supply chain

Combo Excelsior® 1210 standard footprint, **1,000L** capacity and **3,200kg** dynamic load ensuring an optimized payload during road and railroad transportation.

The best folding ratio on the market with only **354mm incremental** folded height. **7 folded** Combo fit in a standard pallet space, **182 units** folded in standard truck reducing reverse logistics cost and lowering CO2 impact.



Most hygienic and safe foldable IBC

100% safe, easy to clean design from base to lid. No dirt or water traps, bug and needle contamination proof. **100% smooth** and double wall sturdy design increases internal volume and ensures compatibility with high speed filling processes. **Fork tine guides on base**, durable **three skids base** and **anti-slip plugs** reinforce safety and speed handling.

Handling improvement & user friendly

Easily erected and folded by one operator only: unique side walls locking while erecting enable one operator to handle the Combo Excelsior®. Non sequential folding saves time and labor.

Improved ergonomics and set up: easy to open and self locking drop door on front combines easy operator access zone while maintaining the panel strength thanks to it's V shape.

Improved bottom discharge zone speeds up the liner and valve set up and removal: larger access and easy connection design for most valves on the market. Faster removal thanks to easy valve release system.

Reusable dustcover without magnet on discharge zone ensures bottom discharge protection against dirt and can be sealed with “one way” tamper evidence.

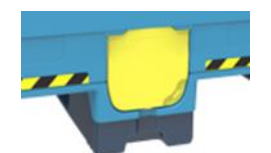
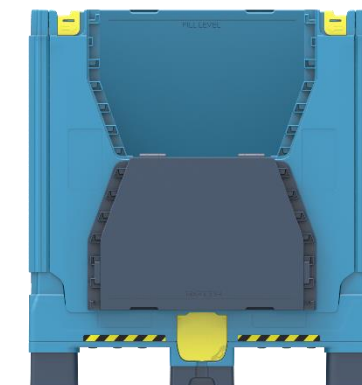

Maintenance

All parts can be replaced increasing significantly **Combo Excelsior®** shelf life.

Thanks to the patented close up bayonet fixing system, the skids can be easily replaced





Features & Benefits

Easy to clean

- Panels and pallet base have a double wall welded structure allowing **100% smooth surfaces** internally and externally and providing more internal volume
- **Rounded corners prevent liner damage**
- **Faster drying design**
- All horizontal surfaces are slanted, allowing **speeding up water drainage and cleaning process**

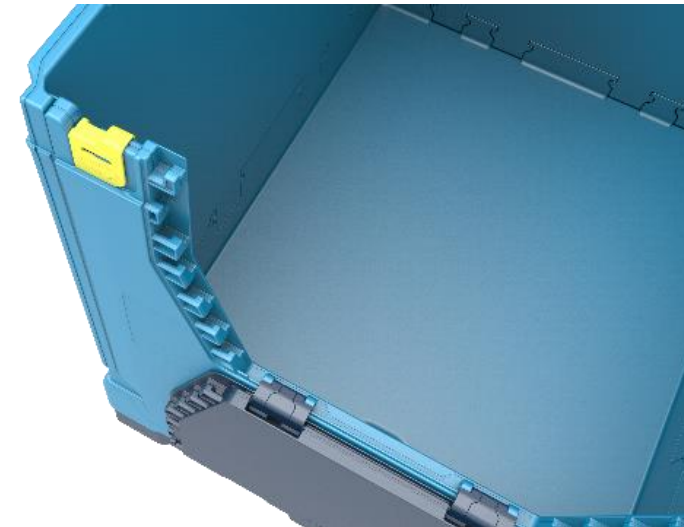

Technology

- **UV treated** and strongly designed the Combo Excelsior® can stay exposed to sun, rain, frost for years without any damage being caused to its structure
- **Interlocking** : “T shaped” hinges on panel ends ensure 100% safe stacking up to 4/1 when filled

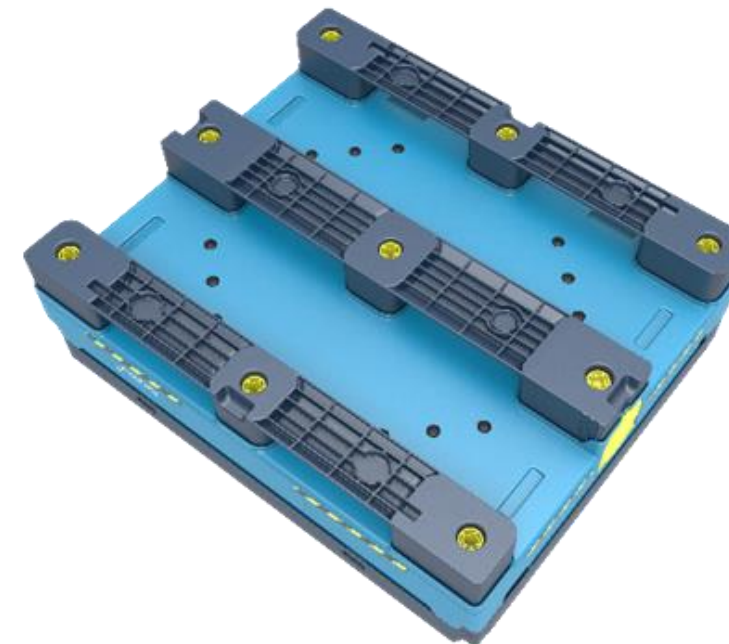
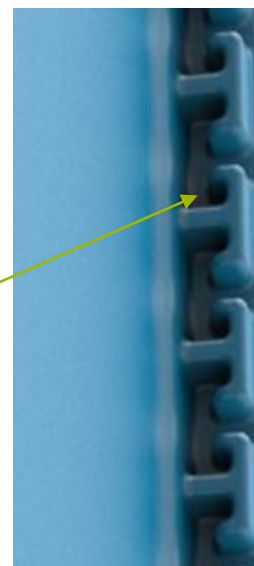

Handling compatibility

- **Fully compatible** with most conveying and automated handling devices and with robotized high speed filling and emptying
- **Compatible** with standard forklifts, pallet jacks, electrical forklifts

Safe & easy handling

- **Non sequential folding and erecting** giving labour saving and process efficiencies
- **Side walls are kept straight while erecting the ends** to maximize safety and operators handling
- **2 side catch wall locking mechanism enabling** one operator only to erect the Combo Excelsior®
- **Anti-slip plugs** on pallet base for safe forklift handling
- **3 skids self-locked** when stacked





Features & Benefits

Seamless construction

- **Smooth design from base to lid**, thanks to the double welded wall structure, promoting hygiene while increasing strength and **usable volume**
- **Plastic outer parts** - No steel parts visible



Contamination & foreign bodies

- Once erected with lid on, **Combo Excelsior® is water tight, dust tight and bug tight**
- The safe design is also **needle proof** to avoid any deliberate contamination

Additional features

- **Secure hinge design** allowing fast fitting, easy maintenance & repairs
- **Maximum fill level indicator** engraved on the inner wall
- **Filling level Liters/Gallons**

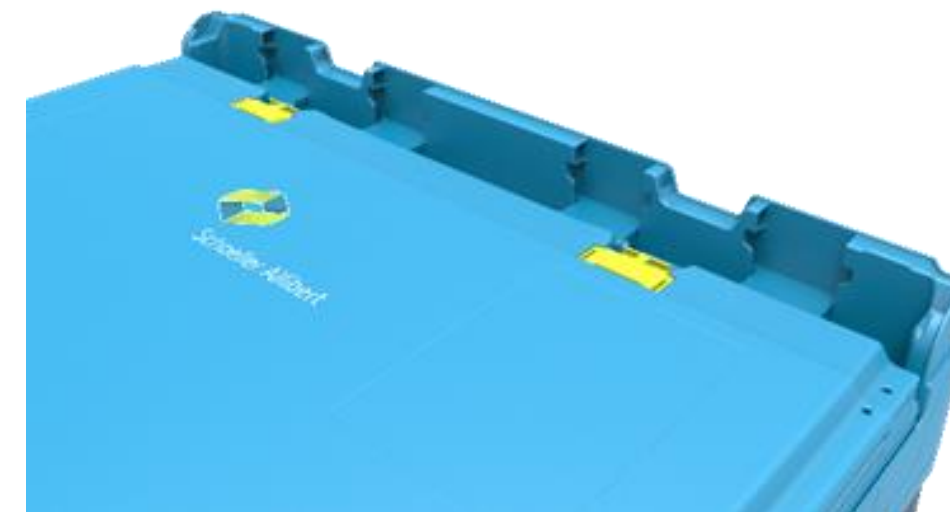

Ergonomics

- Easy unlocking of sides thanks to the **latches hidden** under the lid when closed
- **Ledge on base face** preventing damages to hinges from outside impacts of fork tines





Drop door concept

Design

- **Large door, V-shaped** for improved pressure distribution
- **Easier access** to the bottom discharge zone thanks to low level door opening which allows better liner bag fitting access and removal
- Large **label area** 300x180 mm

Hinges

- **Hinges hidden** in the double wall structure for fully smooth aspect
- **Hinge design** allowing fast & easy maintenance or repairs

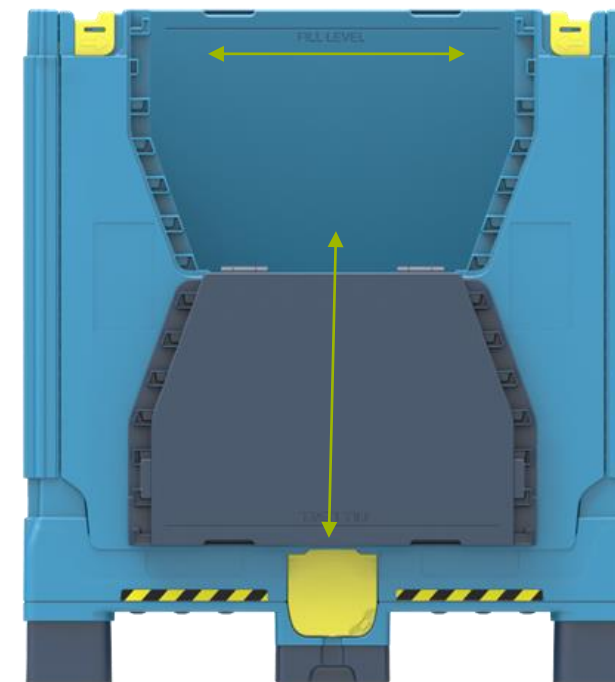
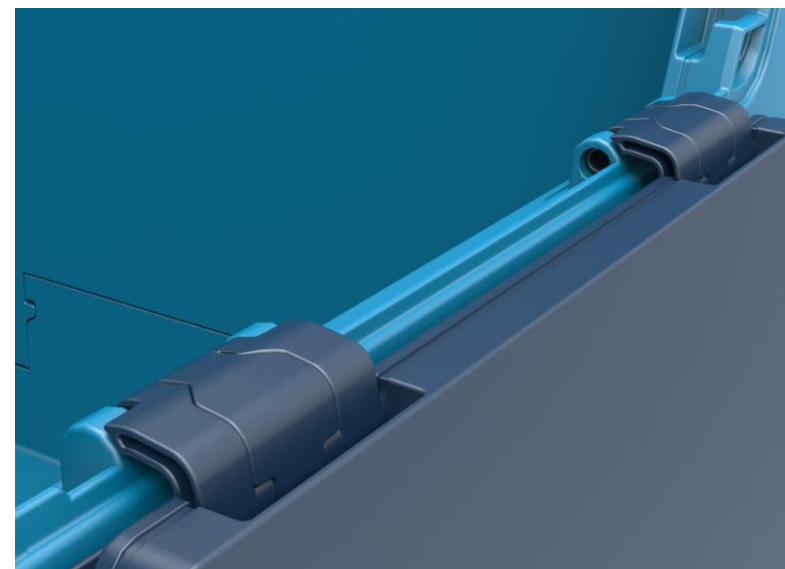

Safer & faster handling

- **Unique self locking mechanism**, for operator comfort and time saved during handling
- **Door handling** simply lift and pull the door
- **Closure**, simple push and no need to lift and push the door
- **Two large hand grips** allow an ergonomic handling
- Drop door remains locked when lid is on, **no risk on having unexpected opening** during transport or handlings





Lid features

Stackability

- **Stacking / centering blocks** on the lid fit in the skids recesses for even more safety at stacking

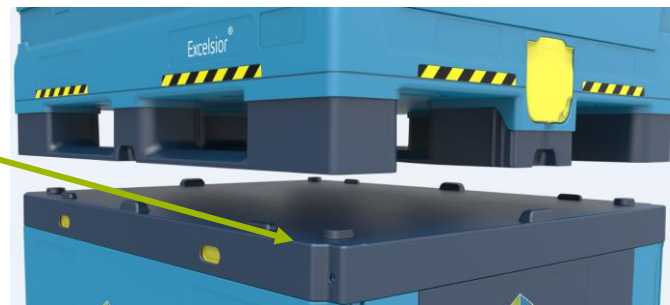

Self-locking system

- **Unique, innovative & SA exclusive** to improve customer experience
- The lid features **self locking latches** for easy handling, time saving and safety

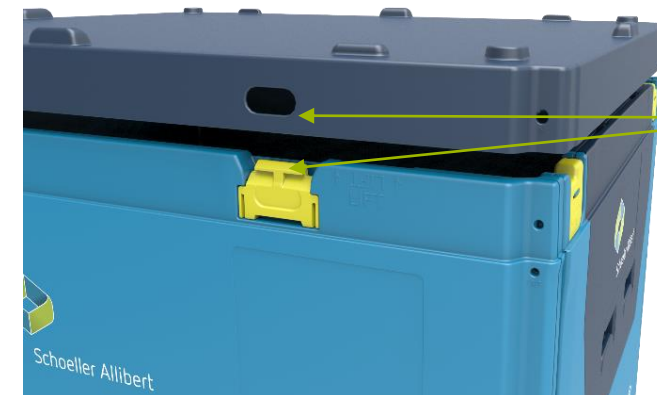

Traceability

- **Strapping, tamper evidence** features make Combo Excelsior® a fully adapted asset for high value ingredients /aromas and cosmetics and comply with **Food Safety norms like IFS**
- **Standard tamper evidence**
- **Tamper evidences are protected** during transport and handlings due panel design recess

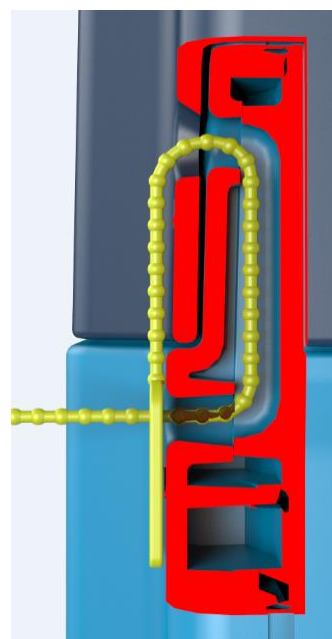

Safer and faster handling

- **The double skin smooth lid** overlapping the side latches ensures extra safety and strength
- **The inner lip/ step inside the lid** prevents the **panels from bending** inwards during storage and shipping
- **Sliding lid on long side** thanks to angled end of lip for improved ergonomics





Hybrid base concept & Releasy® mechanism

Outlets & Compatibility

- Unique, innovative & SA exclusive to improve customer experience
- Easy Schoeller Allibert outlet release device for faster liner fitting and removal
- Fully compatible with the new Schoeller Allibert Speedy® valves & Releasy® outlets & DN50 hooks
- Also compatible with the most common SH outlets in the market (CL285)

Bottom discharge features

- Bottom discharge location (direct liner bag access —)
- New large sump area to improve outlet fitting & liner positioning?
- Top hooks for Speedy® Valves
- Wide bottom rib for clips & valves fitting
- “Releaser” button, slider integrated in the pallet base

Side hooks

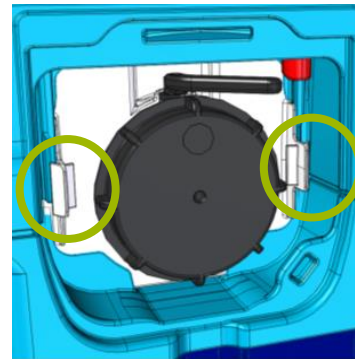

Releasy®

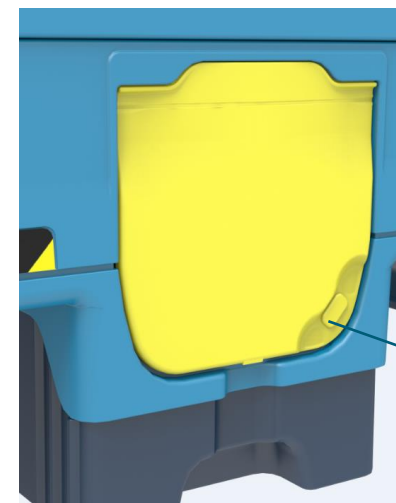
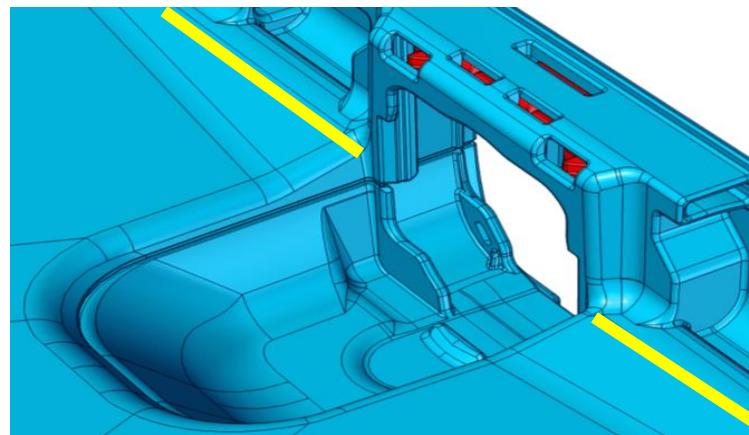
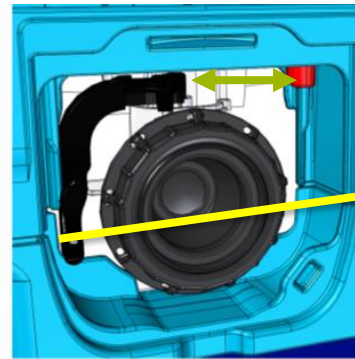

Improved design

- Discharged flow and liner residue improved due to the bottom discharge location combined with new large sump
- Valves and outlets strongly kept in housing (pipe weight & bag roller)
- Releasy® new concept easy to fit and remove outlets, user friendly
- Maintenance cost saving with less damage on the pallet base

Dust cover

- 100% plastic (no magnets)
- Re-usable dust cover
- Self locked “ON” position
- Dustcover on bottom discharge zone for maximized hygiene during empty logistics and handling
- Can be sealed with tamper evidence, standard supplied with blind plug (hole seal)

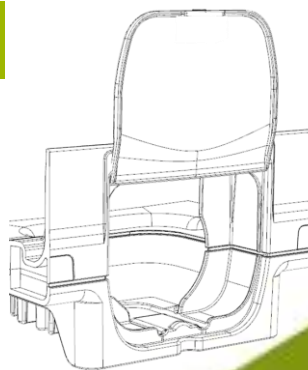

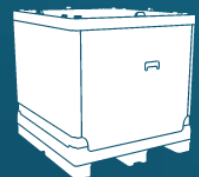

Combo Excelsior® Technical Specifications



5602.301 – 1000L

Ext. (mm)	1219 x 1016 x 1147
Int. (mm)	1142 x 935 x 943
Weight (Kg)	102
Folded height (mm)	374
Incremental (mm)	354
St. height (mm)	1126,7
Folding ratio	70 %
Unit load (Kg)	1500
Stack load (Kg)	8000 (4/1)
Dynamic load (Kg)	3200 (2/1)
Racking load (Kg)	1500
Standard colour	626

Lid included
Hybrid bottom discharge

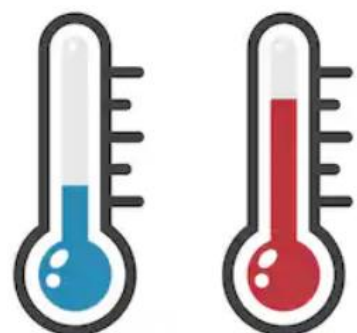

Temperature range
-20°C up to +40°C



Stacking test
7900 kg at 40°C for 1 month





Key industries



Beverage



Food



Agriculture



Pooling

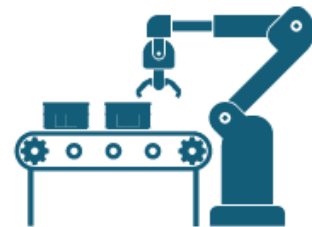

Industrial
Manufacturing
& Recycling



Retail

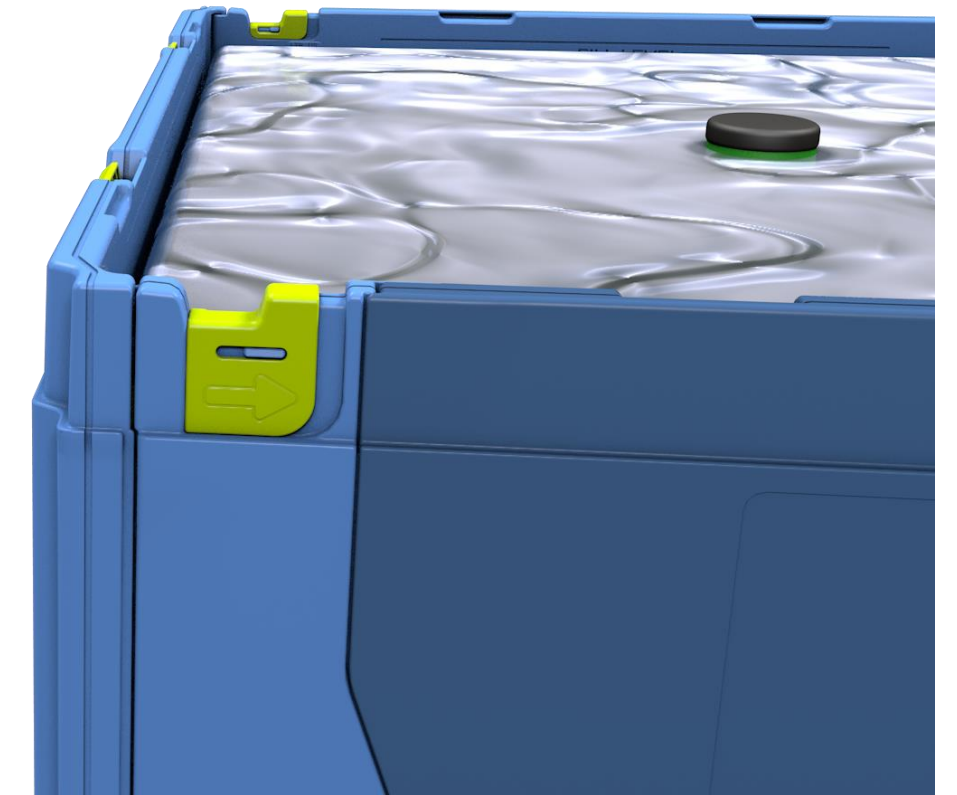

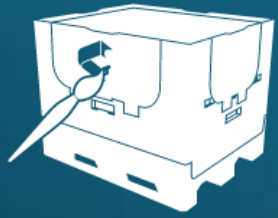

Colour scheme & spare parts

Customization & Decoration

- Decoration areas on the **long sides**
- **Company name** and logo enhance brand awareness and facilitate fleet management
- **Handling instructions** on the base for easy identification of folded IBCs
- **Self adhesive and bar code labels** areas on 4 walls
- Recesses and pockets for **RFID tagging** and **IOT beacons**



Printing & colour

- **Logo feasible** on each sidewall through silk screen printing or adhesive label
- **Engraving insert (pallet base)**
- **Customized mold insert name/logo or production year**
- **Specific color from 2,000 pcs MOQ**, feasibility to be validated by technical department



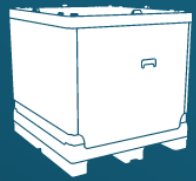

Tamper evident cover

Tamper evident security seal **A199580020** (cfr ALC's), easy to fit and remove.
Extra customization possible through incremental numbering *or barcode engraving* => subject to MOQ.

Tamper Evident seal

Tensile strength : 4,5 kg

Options :

- Incremental numbering
 - Barcode ID
- Both subject to MOQ*

Applications :

Chemics
Pharmaceuticals
Retail
Utilities
Transport & logistics



Standard colours :

Yellow
Red
White
Blue
Green

Materials :

Polypropylene



Schoeller Allibert



Handling instructions

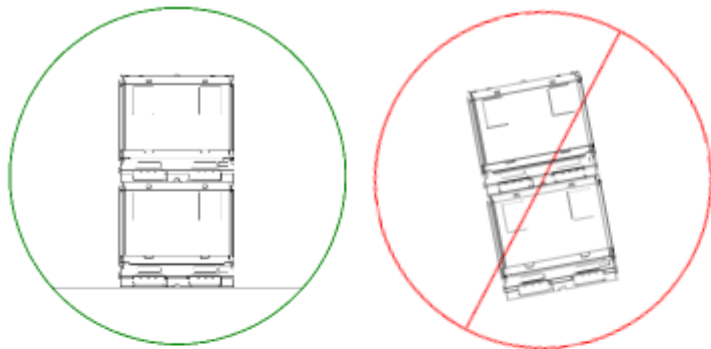

When containers are erected / stacked, all stacks must be on an even surface

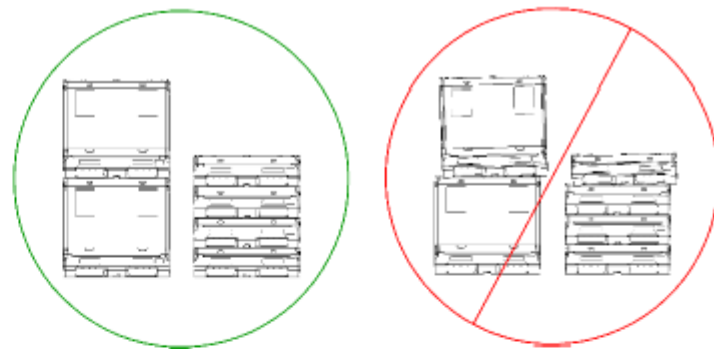

The containers must be properly located and level within the carrier dimensions. Storage and transportation must take max. load performance into account

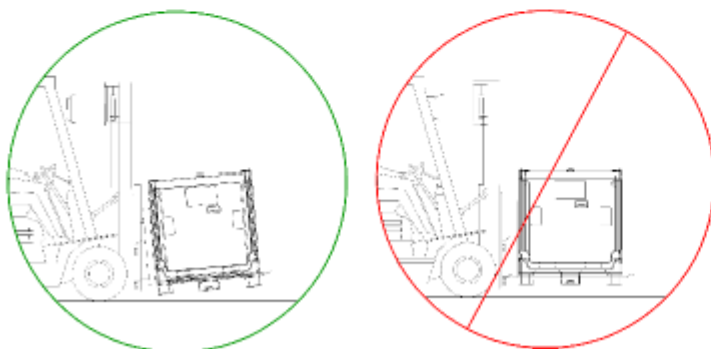

If transported by forklift, the load must be inclined towards the lift operator

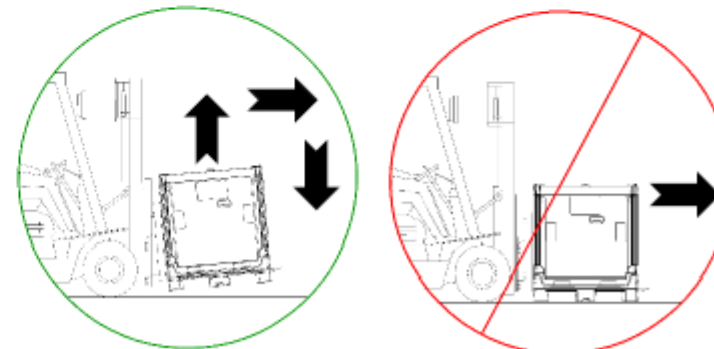

Never push the container along the floor with a forklift truck. Always lift the container from the ground

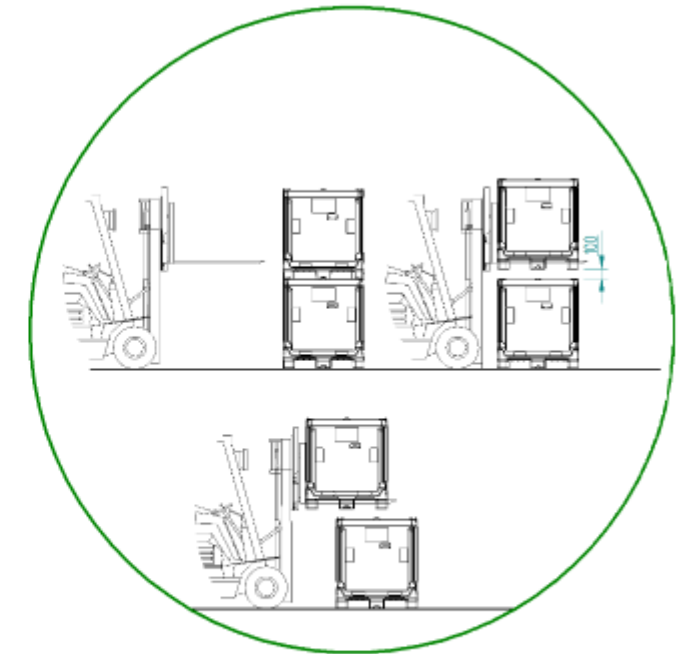
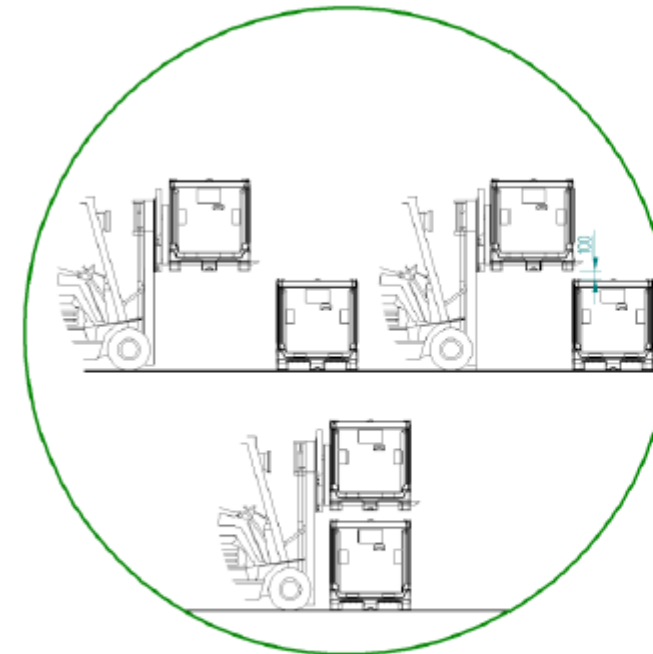

During stacking and unstacking, always lift the container up before moving it horizontally. Always keep minimum safety vertical distance of 100mm from bottom container during horizontal movement. For handling of folded containers apply the same principles.



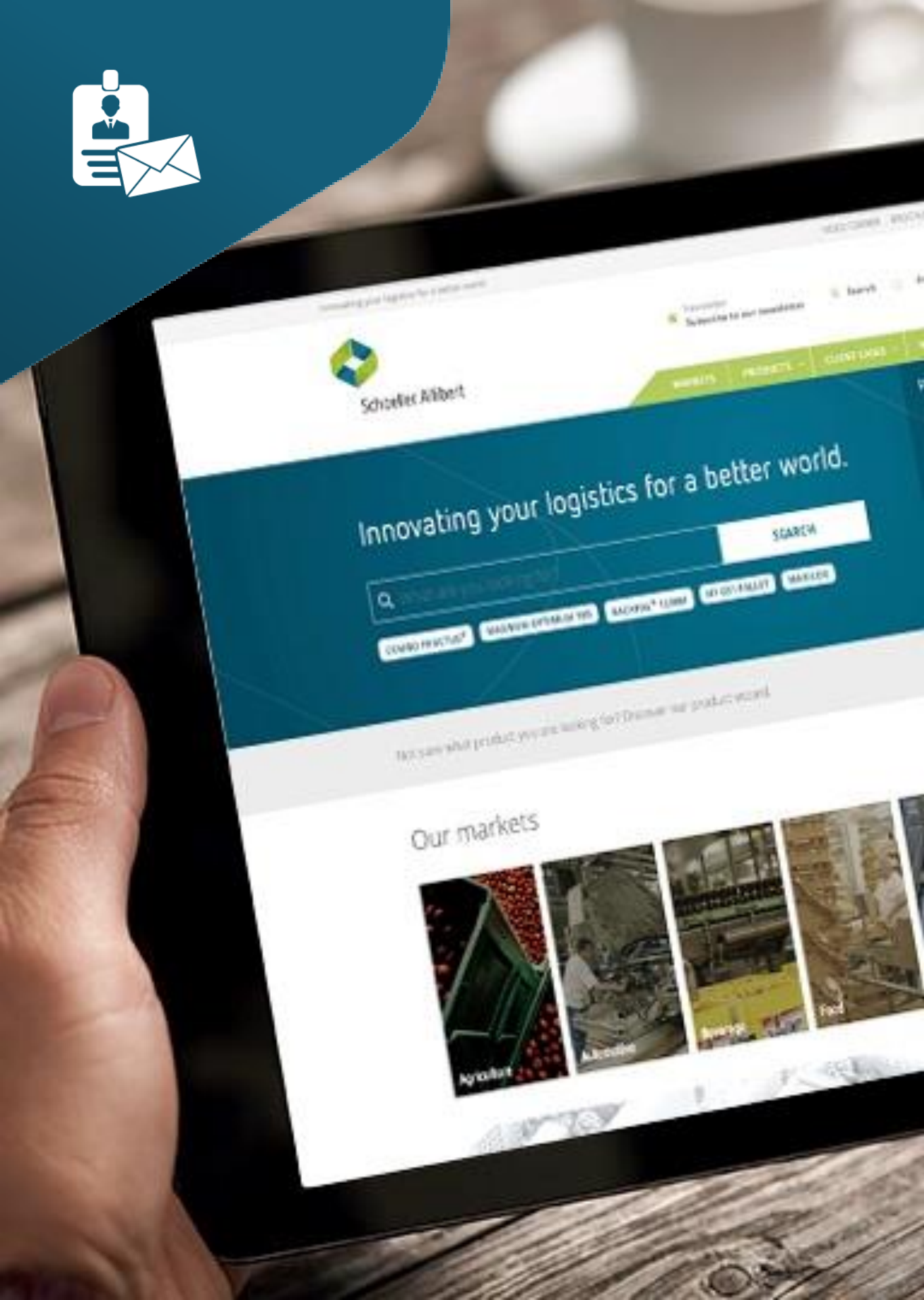

www.schoellerallibert.com

webshop.schoellerallibert.com



Innovating your logistics for a better world



Schoeller Allibert